

CARBON DIOXIDE CO₂

Industrial fire suppression systems



Kidde engineers developed carbon dioxide fire extinguishing over 60 years ago and Kidde have been responsible for every major improvement that has been made in this branch of fire protection. Kidde Fire Protection benefits from the accumulated experience of thousands of installations in power plants, industrial plants, oil refineries, electronic processes, on ships and in a wide variety of hazardous areas.

CO₂ is versatile

The CO₂ is stored as liquid, under pressure. When a system is activated, the liquid CO₂ flows through discharge pipework to specially designed nozzles. The agent's low boiling point means that the liquid vaporises rapidly during the discharge, providing a penetrative three-dimensional action. The rapid expansion of the gaseous agent allows fires to be targeted even in the most inaccessible areas of the risk.

Fire is extinguished by reducing the oxygen level in the risk area to the point where combustion cannot be sustained. Cooling is a secondary action of the agent; this feature is used in local applications where the liquid phase of the discharge is applied directly to the fire and risk materials.

CO₂ is fast and efficient

The Kidde High Pressure CO₂ system uses a large bore discharge valve, enabling high mass flow rates to be achieved. The fast action of the

control system and valve enables the system to react within the first few seconds of a fire that can make the difference between a nuisance and a disaster.

CO₂ is clean

CO₂ is a colourless, odourless, dry, inert gas and is one of the most familiar of all chemicals. After extinguishing a fire it vapourises fully leaving no residue. There is no mess, nothing to clear up, no water damage. It is non-corrosive and will not contaminate foodstuffs. It is non-conductive and so can be used on energised electrical equipment. It is safely used to protect delicate electrical equipment, antiques or archive materials.

CO₂ is low cost

Carbon dioxide is a standard commercial product with many other uses and it is readily available throughout the world. Because of its universal use it can be obtained cheaply and this is an important consideration when frequent recharging of storage containers is





Control head with pilot cylinder



Solenoid for control head



Klem valve with metron actuator



Klem valve with solenoid actuation



Discharge nozzles



Manual pull box



Pressure Switch



Pressure Trip

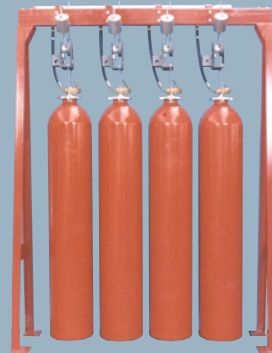

Cylinder contents monitoring option

necessary as in local application systems, where fires may be more frequent.

Benefits

- High flow 'Klem' valve
- Manual or Automatic operation
- Pilot cylinder or Direct Acting Solenoid options
- Continuous weight monitoring option
- Design compliance with BS5306-4
- Fully compatible with Kidde Extinguishing Control Panels

Typical applications

- Flammable liquid storage areas
- Printing presses, flow solder machines
- Quench tanks/exhaust fume ducts
- Paint spray booths
- Fryers/ovens
- EDP/computer rooms and floor voids*
- Commercial kitchens
- Industrial Fryers/ovens
- Transformers
- Generators

* CO₂ is not the agent of choice for manned areas, please contact KFP applications for more information.

System design

Details of both total flooding and local application systems are contained in the KFP CO₂ Design Manual.

Flexible design

The wide range of components manufactured by Kidde enables systems to be engineered to suit individual customer requirements. Systems can be either automatically or manually operated and arranged to protect single or multi-zone hazards and with any number of reserve discharges. Automatic control can be achieved mechanically, pneumatically or electronically or by any combination of these to suit site conditions.

Facilities are available for providing a pre-alarm and delayed discharge as well as various methods of preventing automatic release while protected rooms are occupied by personnel.

Audible and visual indications of system control can be provided together with facilities to automatically shut fuel valves, fire doors, dampers and shutters by either mechanical or electrical devices.

CO₂ is stored in solid drawn steel cylinders manufactured to British Standards. The storage pressure varies with ambient temperature but is 58.6 bar at 21°C.

Any number of cylinders can be manifolded together and simultaneously released to provide the total design requirement of CO₂.

Approvals

Major approvals for the Kidde Fire Protection CO₂ system include:

- Factory Mutual (FM)
- Lloyds
- American Bureau of Shipping
- Det Norske Veritas
- Maritime and Coastguard Agency (UK DETR)
- Germanischer Lloyd



Extinguishing Control Panel

3 CARBON DIOXIDE CO₂

Total Flooding Systems

Total flooding systems extinguish fires by rapidly discharging CO₂ into an enclosed volume to create an atmosphere that is incapable of supporting combustion.

The agent mixes homogeneously within the risk area to generate a CO₂ concentration by volume of at least 34%. This concentration of CO₂ presents a serious hazard to personnel and under no circumstances should CO₂ be released into areas that may be manned at the time of discharge.

Total flood CO₂ systems are ideal for unmanned applications such as transformer rooms, remote switch rooms, generators and archives. All systems should be installed with safety systems in place to prevent the inadvertent release of agent into occupied spaces. Kidde offer time delays, isolating valves including distribution valves and control head lockout pins to facilitate the safe use of CO₂.

Legend

- 1 CO₂ cylinder assembly
- 2 Cylinder valve and actuator
- 3 Solenoid
- 4 Nitrogen pilot cylinder and control head
- 5 Manual push button
- 6 Pressure relief device
- 7 Isolating ball valve
- 8 Discharge pressure switch
- 9 Pilot bleed
- 10 Pressure trip
- 11 Extinguishing control panel
- 12 Status indicator unit
- 13 Status indicator with release control
- 14 1st stage alarm sounder
- 15 2nd stage alarm sounder
- 16 Discharge nozzle
- 17 Fire door
- 18 Smoke detector

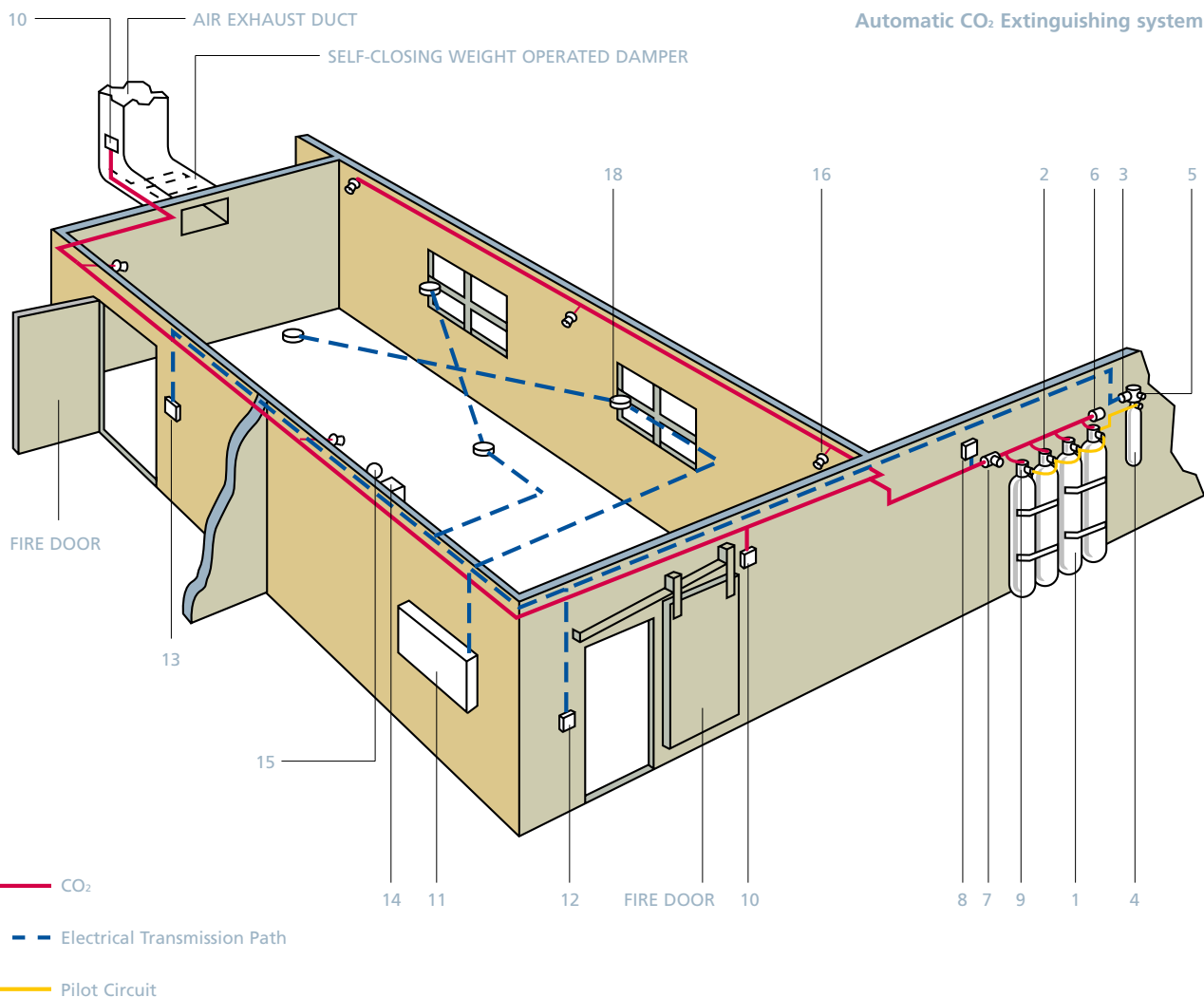



System Information
Total Flooding Systems

Surface Fires

Fires involving flammable liquids, gases or solid materials not subject to smouldering are known as surface type fires.

The design concentration of CO₂ provided must be maintained for 10 minutes.

Basic quantities of carbon dioxide for various space volumes may be calculated from Table 1.

The basic quantity of CO₂ is factored according to the risk material. Some typical values are shown in Table 2.

Deep Seated Fires

A fire involving a solid material that is subject to smouldering is called a deep seated fire.

Rooms containing these materials should have no openings that cannot be automatically closed, other than small openings or pressure vents near the top of the enclosure.

Additional quantities of CO₂ are needed and held within the space for not less than 20 minutes.

Recommended design concentrations for various hazards are shown in Table 3.

Integrity and venting requirement

Total flood suppression systems rely on the enclosure retaining the required gas concentration for a period of time known as the hold time. The ability of the hazard enclosure to retain the gas for the required hold is usually determined by door fan integrity

testing. If the test shows that the leakage would reduce the hold time below that specified for the fire type, additional CO₂ must be provided.

The release of CO₂ into a tightly sealed enclosure could result in damage caused by pressure variations during discharge. Normally the natural leakage of an enclosure is adequate to prevent damage but in some cases pressure relief venting may be required.

System Information
Local Application Systems

Volume Method

The volume method of system design is used where the fire hazard consists of three dimensional irregular objects that cannot easily be reduced to equivalent surface area.

The total discharge rate of the system is based on the volume of an assumed enclosure surrounding the hazard. The basic design rate is 16 kg min m⁻³ but this can be reduced according to the degree of existing enclosure on site.

Area Method

The quantity of carbon dioxide required is based upon the total discharge rate from a carefully sited nozzle arrangement, a sufficient number of nozzles being used to adequately cover the entire area on the basis of the unit area protected by each nozzle.

For this method of design, where a horizontal or vertical flat surface is protected, nozzles are to be positioned in accordance with the guidance of the Kidde CO₂ design manual. The position and distance from the hazard has a critical effect

on the quantity of CO₂ required. This protection methodology is well suited to painting, dipping and drying type applications.

Table 1
– to determine basic CO₂ quantity

| Volume - m ³ | | Factor - kg.m ³ |
|-------------------------|-------|----------------------------|
| >4 | >14 | 1.15 |
| >4 | >14 | 1.07 |
| >14 | >45 | 1.01 |
| >45 | >126 | 0.90 |
| >126 | >1400 | 0.80 |
| >1400 | | 0.74 |

Table 2
– to determine higher concentrations for specific hazards

| Capitalise factor | |
|-------------------|-----|
| Acetylene | 2.5 |
| Benzol | 1.1 |
| Butadiene | 1.3 |
| Ethyl Ether | 1.5 |
| Ethylene | 1.6 |
| Hexane | 1.1 |
| Hydrogen | 3.2 |
| Kerosene | 1.0 |
| Petrol | 1.0 |

Note: MCF of 1.0 is equal to a concentration of 34%

Table 3
– concentrations for deep seated hazards (BS5306: 4)

| Hazard | Flooding Factor |
|--------------------------------------|------------------------|
| Dry electrical wiring and insulation | 1.35kg m ⁻³ |
| Computer equipment | 1.50kg m ⁻³ |
| Data processing and tape storage | 2.25kg m ⁻³ |
| Record stores/archives | 2.00kg m ⁻³ |
| Dust collectors | 2.70kg m ⁻³ |

Ordering information for typical pilot cylinder actuated CO₂ system (up to 10 off 45kg cylinders)

| Description | Part No. | 1 | 2 | 3 | 4 | 5 | 6 | 7 | 8 | 9 | 10 |
|--|----------------------------|-----|-----|-----|-----|-----|-----|-----|-----|-----|-----|
| | | Cyl | Cyl | Cyl | Cyl | Cyl | Cyl | Cyl | Cyl | Cyl | Cyl |
| 45 kg CO ₂ Cylinder (full) | K24069/L/R or E7194-007 | 1 | 2 | 3 | 4 | 5 | 6 | 7 | 8 | 9 | 10 |
| 2 Cylinder 1" Manifold | K21207 | | 1 | | | | | | | | |
| 3 Cylinder 1" Manifold | K21209 | | | 1 | | | | | | | |
| 4 Cylinder 1" Manifold | K21211 | | | | 1 | | | | | | |
| 5 Cylinder 1" Manifold | K21213 | | | | | 1 | | | | | |
| Combination of 1" or 1 1/4" manifolds as required | | | | | | | • | • | • | • | • |
| Single Row M/Fold Bt. 1" | K24267D | | 2 | 2 | 2 | 3 | • | • | • | • | • |
| Flexible Loop | K97112 | 1 | 2 | 3 | 4 | 5 | 6 | 7 | 8 | 9 | 10 |
| Pressure/Lever Actuator | K62341 | 1 | 2 | 3 | 4 | 5 | 6 | 7 | 8 | 9 | 10 |
| 2 Cylinder Backrack | K17238 | | 2 | | 4 | 2 | | 4 | 2 | | 4 |
| 3 Cylinder Backrack | K17235 | | | 2 | | 2 | 4 | 2 | 4 | 6 | 4 |
| 2 Cylinder Frontstrap | K13744 | | 2 | | 2 | 2 | | 4 | 2 | | 4 |
| 3 Cylinder Frontstrap | K13745 | | | 2 | | 2 | 2 | 2 | 4 | 6 | 4 |
| Single Row Rack Bolt inc nuts | K62752 | | 2 | 4 | 4 | 6 | 8 | 8 | 10 | 12 | 12 |
| Hose/Pipe Adapter | K62755 | 1 | | | | | | | | | |
| System Control Head | K62303 | 1 | 1 | 1 | 1 | 1 | 1 | 1 | 1 | 1 | 1 |
| Solenoid (std) 24V dc | K62422B | 1 | 1 | 1 | 1 | 1 | 1 | 1 | 1 | 1 | 1 |
| Pilot Cylinder | K62462 | 1 | 1 | 1 | 1 | 1 | 1 | 1 | 1 | 1 | 1 |
| Wall Mount | K62487 | 1 | 1 | 1 | 1 | 1 | 1 | 1 | 1 | 1 | 1 |
| Pilot Vent (Bleed) | K24051 | 1 | 1 | 1 | 1 | 1 | 1 | 1 | 1 | 1 | 1 |
| Pilot Loop (Long) | K93434 | 1 | 1 | 1 | 1 | 1 | 1 | 1 | 1 | 1 | 1 |
| Pilot Loop (Short) | K93433 | | 1 | 2 | 3 | 4 | 5 | 6 | 7 | 8 | 9 |
| Single Cylinder Strap | K62943 | 2 | | | | | | | | | |

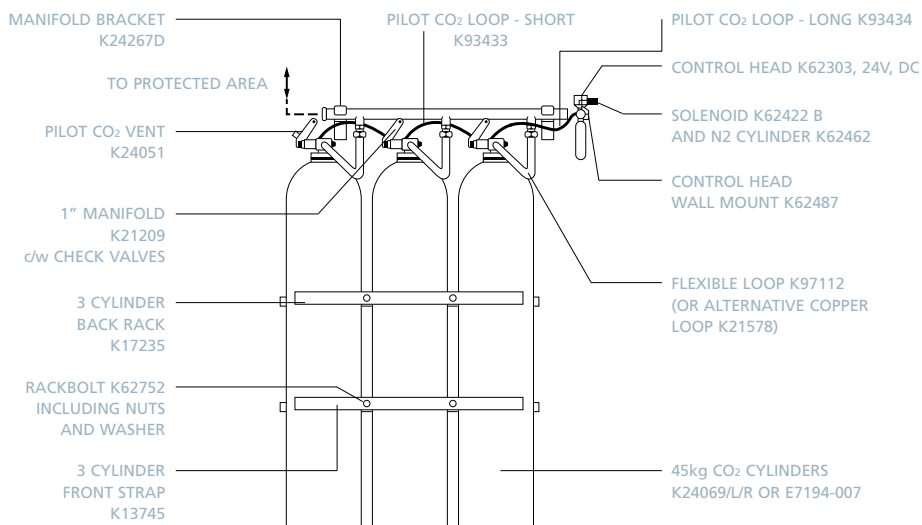
Other equipment to suit specific systems

- Discharge nozzles
- Warning labels (metal or self-adhesive)
- Pressure switch
- Break glass pull box
- Pneumatic time delay unit
- Pressure relief devices
- Pressure Operated Direction valve
- Isolating valve
- Control and detection equipment
- Alarm devices
- Mechanical detection/actuation (As required)

7 ELECTRICALLY ACTUATED CO₂ SYSTEM

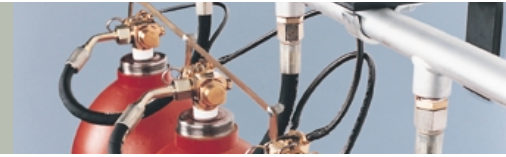

Direct-acting CO₂ Solenoid

Designed for use with standard Kidde 45kg CO₂ cylinders, the direct-acting solenoid allows CO₂ systems to be actuated electrically without the need for a separate pilot nitrogen supply.

The solenoid actuation system utilises a modified version of the existing cylinder valve, replacing the nitrogen pilot cylinder with a solenoid directly coupled to the CO₂ cylinder valve. The system also retains the facility for local manual release or via a mechanical pull cable.

Operation

The pressure/manual actuator (K62341) is fitted to the cylinder (Klem) valve, with the solenoid assembly (D8522-001) attached to the poppet orifice connection by means of a swivel nut and O-ring seal. The solenoid assembly has a flexible hose connection to the pressure/manual actuator.

In the unactivated state, the pneumatic actuator is subject only to atmospheric pressure and the Klem valve remains closed. On receipt of an electrical signal from an extinguishant release control panel, the solenoid coil is activated, releasing high pressure CO₂ from the cylinder. The CO₂ passes through a short flexible hose to the pressure/manual actuator, which then operates the Klem valve, allowing CO₂ to exit via the discharge port. Further CO₂ cylinders may be discharged by interconnecting the pressure/manual actuators using flexible pilot hoses (K93433).

Also available, Metron actuator c/w manual lever (D8521-002), ideal for single cylinder electrical operation.



8 ELECTRICALLY ACTUATED CO₂ SYSTEM

Specification

| | |
|-----------------------------|-------------------------|
| Voltage range | 18V DC to 28V DC |
| Current at 28V DC | 526 mA |
| Minimum firing pulse | 60mS |
| Electrical connection | DIN plug type DIN 43650 |
| Maximum working pressure | 152.5 bar (g) |
| Current at 18V DC | 338 mA |
| Nominal coil resistance | 53.2 ohm |
| Maximum firing pulse | Unlimited |
| Operating temperature range | -20°C to +55°C |
| Environmental protection | BS EN 60529 1991 IP65 |

| Item | Part No. | Description | Quantity |
|------|-----------|--------------------------------|----------|
| 1 | D7226-007 | Klem valve & cylinder assembly | 1 |
| 2 | D8522-001 | Klem valve solenoid assembly | 1 |
| 3 | K93433 | Bundy tube, flexible loop | 1 |
| 4 | K62341 | Actuator, pressure/manual | 1 |
| 5 | D7564-001 | Bleed assembly | 1 |

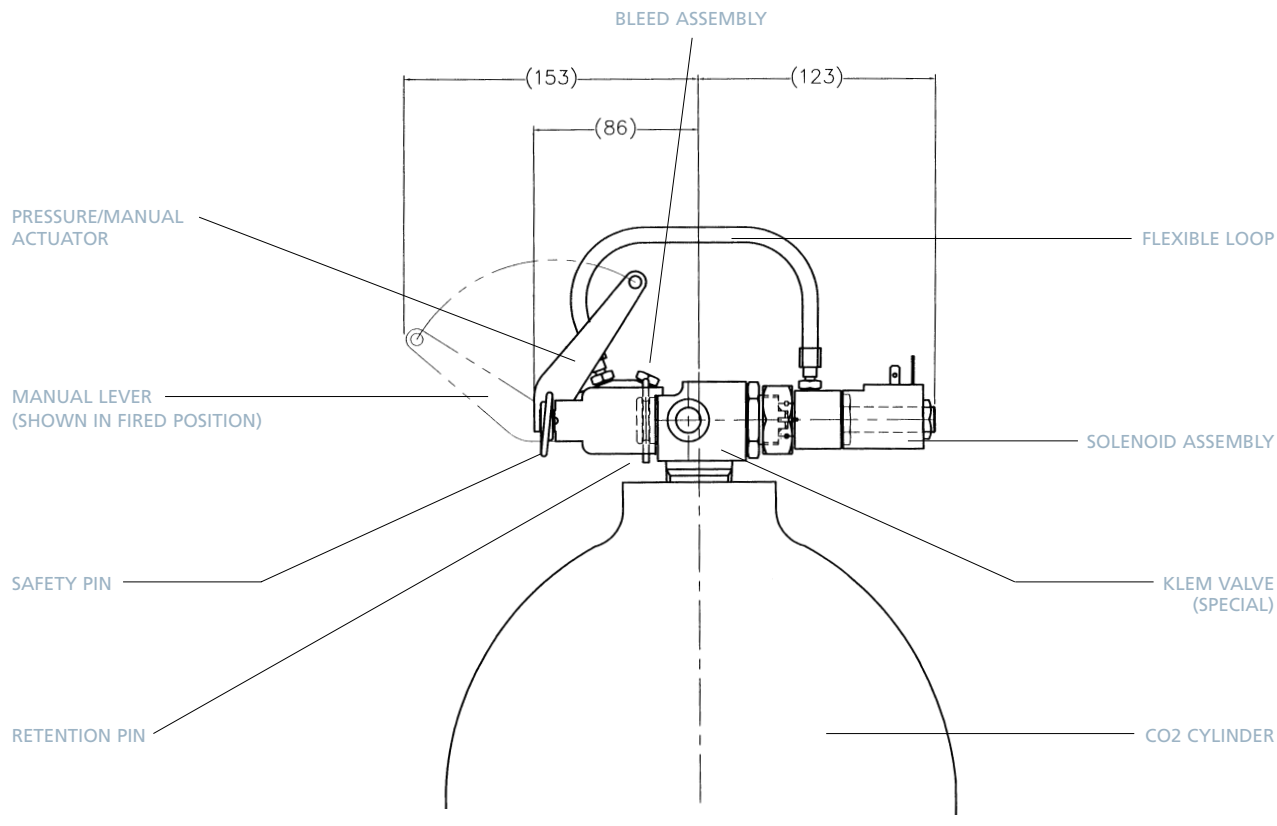

Kidde Fire Protection Limited

UK Sales Office – Head Office

Belvue Road, Northolt, Middlesex UB5 5QW UK.

Tel: +44 (0)20 8839 0700. Fax: +44 (0)20 8845 4304. E-mail: info@kfp.co.uk Web: www.kfp.co.uk

UK Sales Office

Unit 12, Atley Way, North Nelson Industrial Estate, Cramlington, Northumberland NE23 1WA UK

Tel: +44 (0)1670 713455. Fax: +44 (0)1670 735553

International Offices

Dubai: Tel: +971 4 337 2498. Fax: +971 4 337 5088

Hong Kong: Tel: +852 2195 3688. Fax: +852 2743 7477

Singapore: Tel: +65 392 2282. Fax: +65 392 2272

Melbourne: Tel: +61 3 9721 3850. Fax: +61 3 9729 2019